

BYA	BYA	BYA
50.1 m <sup>2</sup>	2.7 m <sup>2</sup>	5.6 m <sup>2</sup>
BRA	BRA	BRA
44.2 m <sup>2</sup>	2.3 m <sup>2</sup>	4.9 m <sup>2</sup>
Gr.fl.		
48.8 m <sup>2</sup>		

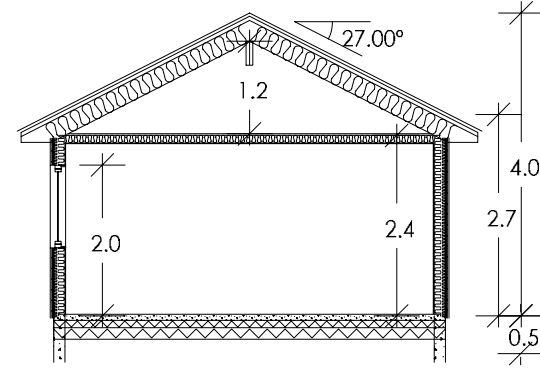

Arealberegninger i hht. NS 3940	Bruksareal BRA i m <sup>2</sup>
1. etg. plan	44.2
SUM:	44.2
BYA:	50.1
Grunnflate/følavtvkk:	48.8
Apert overbyggareal	7.2
Sum BRA	51.4
	7.2
	51.4
	58.4



Pro: R. 1K007	REV	ANT.	REVIDERING GJELDER	DATE	SIGN.
Tegn: 501	Godkjent av kunde:				
Målt: 100	Modell: Driva				
Tegn:	Byggherre:				
Dato: 12.07.2018	Byggeplass:				
<small>ARBEIDER SOM IKKE RANA FYTTA BERNHARD OLSEN AS MEDVIRKER I.</small>					
<small>TEGNINGEN MÅ HVERKEN HJELPES ELLER BENYTTES VED</small>					
<small>Bygget er ikke teknisk prosjektert og mindre endringer kan forekomme.</small>					